

## Pressure control coupler F239



---

### 01 Pressure control coupler F239

The Meggitt air set pressure control coupler is designed to mate with EI standard hydrants or hydrants and adapters manufactured in accordance with EI 1584 4th Edition. Control pressure is achieved by the use of regulated reference air and remote fuel sense pressure. Available options include air deadman only and local sensing. Outlet configurations allow the use of various types of threads and hose sizes. (Supersedes F229 series pressure control coupler.)

#### Additional features

- Texin bumper reduces coupler wear and breakage
- Pressure drop thru the F239 pressure control coupler and F352 EI hydrant valve is 12 PSI (0.85 bar) at 1200 GPM (4500L/Min)
- Operating pressure to 200 PSI (13.9 BAR)
- Peak surge pressure 305 PSI (21.0 BAR)
- Does not require a separate lock for the shroud
- Can be used as primary or secondary pressure control

---

### 02 Key Features

- Air and fuel separated by dual sealed dead space vented to atmosphere
- Full size 4-inch flow path
- Available with F554 air/fuel sense plug to mate with F571 air/fuel sense socket
- Operating handle with full interlock feature - will not open unless locked onto the hydrant or adapter, may not be disconnected unless closed
- 4-inch disconnect type swivel with safety and redundant lock rings for positive lock and ease of removal from hose
- Mates with Meggitt hydrants F352/F353 and others which comply with Energy Institute standards, and F414 adapter designed in accordance with API Bulletin 1584

## Pressure control coupler F239

### 03 Key Dimensions

#### Operating characteristics

- Operating pressure - 200 PSI<sup>1</sup>
- Closing time - adjustable 2 to 15 seconds
- Opening time - adjustable 2 to 30 seconds
- Regulated pressure - nominal 25 PSI below air pressure
- Flow characteristics - pressure drop 12 PSI at 1200 GPM mated to F352 hydrant valve
- Requires minimum of 50 PSI regulated air pressure
- Example: 65 PSI air to obtain nominal 40 PSI fuel pressure

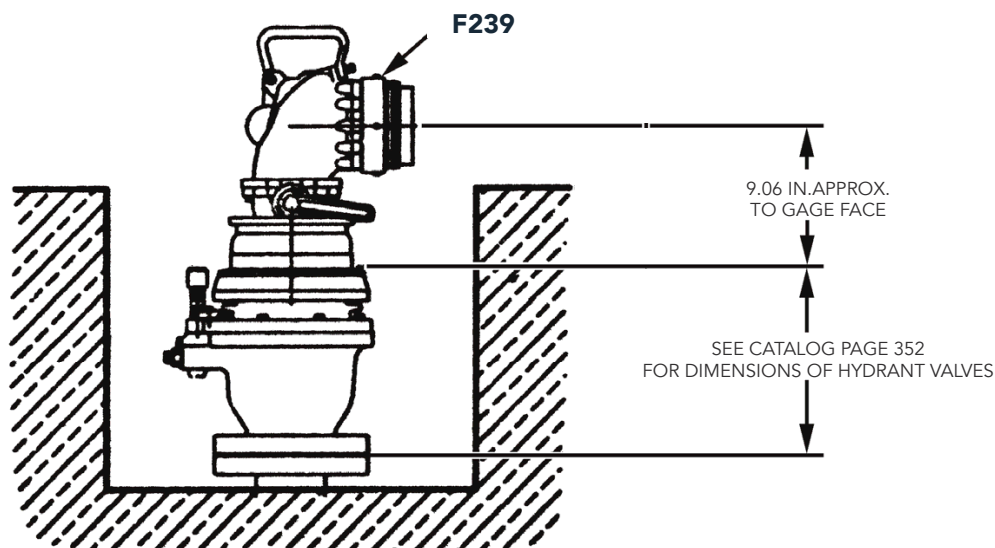

### 04 Contact

#### Meggitt Shanghai Office

Address: Rm1107, Block A, No.319 XianXia Road, Changning District  
Shanghai, China

Telephone: +86 21 6278 1096

Website: <https://www.meggitt.com/products-services/ground-fuelling>

#### Meggitt (Xiamen) Sensors & Control Co., Ltd.

Address: No. 230 South 5 Gaoqi Road, Xiamen 361006,  
P.R. China

Telephone: +86 592 5733 666

Website: [www.meggittxiamen.com/gfp](http://www.meggittxiamen.com/gfp)