

Fuelling products

Couplings

2 1/2-inch self sealing industrial couplings

Specification

2 - TANK UNIT THREADED VERSION CCMY 6251N* 2

Materials	Gunmetal, St/Steel, Structural Plastic
Weight	2.50 kg (5.53 lb)
Max. Working Pressure	175 psi (12 bar)
Test Pressure	265 psi (18 bar)

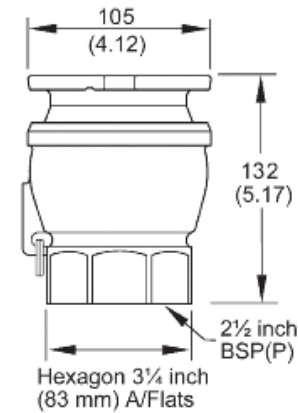

3 - TANK UNIT FLANGED VERSION CCMY 6250N 3

Material	Gunmetal St/Steel, Structural Plastic
Weight	4.7 kg (10.5 lb)
Max. Working Pressure	175 psi (12 bar)
Test Pressure	265 psi (18 bar)

Flanged tank units are normally supplied undrilled, but can be drilled to customer requirements on request

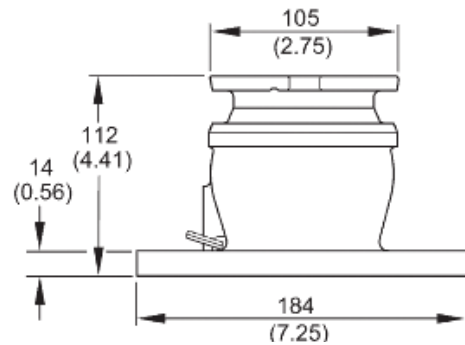

Dimensions in millimeters (inches)

4 - DUST CAP FOR HOSE UNIT CCMY 6* 4

Material	Aluminium Alloy-
Weight	0.25 kg (0.56 lb)



5 - DUST CAP FOR TANK UNIT CCMY 5* 5

Material	Aluminium Alloy
Weight	0.18 kg (0.4 lb)



Meggitt Control Systems

Our product competencies & services:
Aerospace valves | Thermal management solutions | Environmental control systems | Electro-mechanical products
Ground fuelling products | Energy products | Aftermarket services

MEGGITT
smart engineering for
extreme environments