

# Bottom loading coupler F228



## 01 Bottom loading coupler F228

The Meggitt 4-inch bottom loading coupler is designed in accordance with API RP1004.

**NOTES:**

1. Modification A, K & N may be added to the basic F228 and all other modifications
2. Modification C may be used in conjunction with all other modifications
3. Modifications D, F, & G are separate modifications and cannot be combined with each other

**F228 Dimensions**

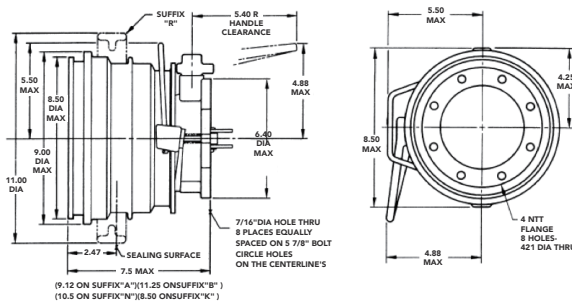

## 02 Key Features

- Push-on, pull-off, one-hand operation no rotation, no slots
- Fully interlocked - can't be opened unless locked and can't be removed unless closed
- Minimum disconnect spillage with dual seals within API specs
- Floating nose seal provides positive seal under operating conditions
- Dust protection sleeve seal
- Full flow 4-inch design - 4.7 PSI pressure drop thru F228/F433 at 1000 gpm
- Lightweight design - 13.6 pounds
- 4-inch NTT flanged inlet standard, other options available as listed below
- Mates adapters made to API PR1004
- Standard seals recommended for all commercial automotive and aircraft fuels, Viton seals available
- Meggitt 4-inch swivels available as modifications
- Operating pressure - 120 PSI maximum, 350 PSI peak surge

## 03 Contact

**Meggitt Shanghai Office**

Address: Rm1107, Block A, No.319 XianXia Road, Changning District Shanghai, China

Telephone: +86 21 6278 1096

Website: <https://www.meggitt.com/products-services/ground-fuelling>

**Meggitt (Xiamen) Sensors & Control Co., Ltd.**

Address: No. 230 South 5 Gaoqi Road, Xiamen 361006, P.R. China

Telephone: +86 592 5733 666

Website: [www.meggittxiamen.com/gfp](http://www.meggittxiamen.com/gfp)